

90° Optical Hybrids and Integrated Receivers For Coherent Detections

Optoplex Corporation
Fremont, CA 94538
USA

--- 2025 ---

Table of Contents

1. Introduction	4
1.1 Optoplex's 90deg Optical Hybrid.....	4
1.1 Other Products Described int this document	4
2. 90deg Optical Hybrid	5
2.1 Functional Diagram	5
2.2 Balanced Detection	5
2.3 Performance Specifications of 90deg Optical Hybrid	6
2.3 Mechanical Dimension	7
2.3.1, Mechanical Drawing.....	7
2.3.2, Port Assignment.....	8
2.4 Typical Part Numbers of 90deg Optical Hybrids.....	8
3. 90deg Optical Hybrid with Single-ended PD Outputs.....	11
3.1 Functional Block Diagram.....	11
3.2 Mechanical Drawing.....	11
3.3 Photodiode Properties.....	12
3.3.1 PDs with 0.6GHz BW.....	12
3.3.2 PDs with 3GHz BW.....	12
3.3.3 PDs with 7GHz BW.....	13
3.4 Part Numbers and Ordering Information	13
4. 90deg Optical Hybrid integrated with Balanced Receivers	15
4.1 Introduction	15
4.2 Max Absolute Ratings	15
4.3 Operating Conditions.....	16
4.4, Balanced Receiver Specifications.....	16
4.4.1 General Requirements	16
4.4.2 Electrical Performance Specifications of Balanced Receivers	17
4.5, List of Part Numbers of 90deg Optical Hybrid Integrated Receivers	18
4.6, Mechanical Drawings of 90deg Optical Hybrid Integrated Receiver	19
5. Phase-Tunable 90deg Optical Hybrids	20
5.1 Introduction	20
5.2. Physical Properties.....	20
5.2.1, Device Dimension	20
5.2.2, Mechanical Drawing.....	20
5.3 Phase-Tuning Performance.....	21

5.4, Phase Tuning Pin Definition.....	22
5.4.1 Electrical Control Pin (for Phase-Tuning) Assignments.....	22
5.4.2 Function Definitions of the Phase-Tuning PINs	22
5.5, Popular Part Numbers of Phase-Tunable 90deg Optical Hybrids.....	24
6. 2x8 DP-QPSK Coherent Mixer (aka Polarization-Diversified 90deg Hybrid).....	25
6.1. Functional Diagram	25
6.2. Port Definition	25
6.3. Specifications.....	26
6.4. Mechanical Properties	27
6.4.1 Device Dimension	27
6.4.2 Mechanical Drawings	27
6.5. Port Assignment	27
6.6 Part Numbers of 2x8 DP-QPSK Coherent Mixers.....	28
7. 2x8 DP-QPSK Coherent Mixer with Single-ended PD Outputs.....	29
7.1 Functional Block Diagram.....	29
7.2 Performance.....	29
7.3 List of Part Numbers of 2x8 DP-QPSK Coherent Mixer with Single-ended PD Outputs.....	30
8. 2x8 DP-QPSK Coherent Mixer integrated with Balanced Receivers	31
8.1 Functional Block Diagram.....	31
8.2 Performance Specifications	31
8.3 List of Part Numbers of 2x8 DP-QPSK Coherent Mixer with Balanced Receivers	32
9. 2x4 DP-QSK Coherent Mixer for Single-ended Detection	33
9.1 Functional Diagram	33
9.2 Port Definition	33
9.3 Performance Specification.....	34
9.4 Part Numbers and Ordering Info	35
10. 180deg Optical Hybrids.....	35
10.1 Functional Diagram	35
10.2 Performance Specifications	36
10.3 Mechanical Drawings	37
10.4 List of Part Numbers and Ordering Information.....	37

1. Introduction

1.1 Optoplex's 90deg Optical Hybrid

To be used for optical coherent detection, including QPSK receiver, Optoplex's six-port **90° Optical Hybrid** mixes the incoming signal with the reference signal to generate four quadratural states in the complex-field space. The optical hybrid then delivers the four light signals to two pairs of balanced detectors. See the block diagram below for the application of 90° Optical Hybrid in a coherent receiver.

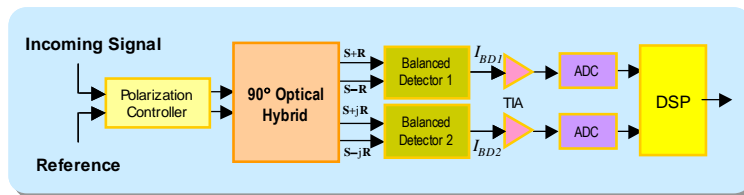

Figure 1.1, 90deg Optical Hybrid in a Coherent Detection System

Optoplex's free-space micro-optics-based, **passive** 90° Optical Hybrid is suitable for *coherent signal demodulation*, BPSK or QPSK demodulation. The patent-pending, broadband device accepts the two optical signals (S & L) and generates four output signals: S+L, S-L, S+jL, S-jL, as shown below. When these signals are detected by two balanced receivers, both the amplitude and the relative phase information between the input signals can be extracted via differential detection and digital signal processing. Moreover, in a coherent system, the preservation of the optical phase can be used to cost-effectively compensate optical transmission impairments in the electrical domain.

Key Features and Benefits

- Purely passive (no need for external electric power)
- Compact size
- Based on free-space bulk-optics design
- Polarization diversified version also available

Applications

- QPSK and BPSK optical demodulations in optical communications
- Coherent doppler lidars
- Coherent detection in a DAS sensing
- Coherent detection in biomedical imaging, e.g., OCT
- Quantum communications systems
 - High CMRR coherent receivers
 - Quantum Random Noise Generators (QRNG)
- Quantum Sensors

1.1 Other Products Described in this document

- 90deg Optical Hybrids
- 90deg Optical Hybrid with PD Outputs
- 90deg Optical Hybrid integrated with Balanced Receivers
- Phase-Tunable 90deg Optical Hybrids
- 180deg Optical Hybrids
- 2x8 DP-QPSK Coherent Mixers
- 2x8 DP-QPSK Coherent Mixer with PD Outputs
- 2x8 DP-QPSK Coherent Mixer Integrated with Balanced Receivers
- 2x4 DP-QPSK Coherent Mixers

2. 90deg Optical Hybrid

2.1 Functional Diagram

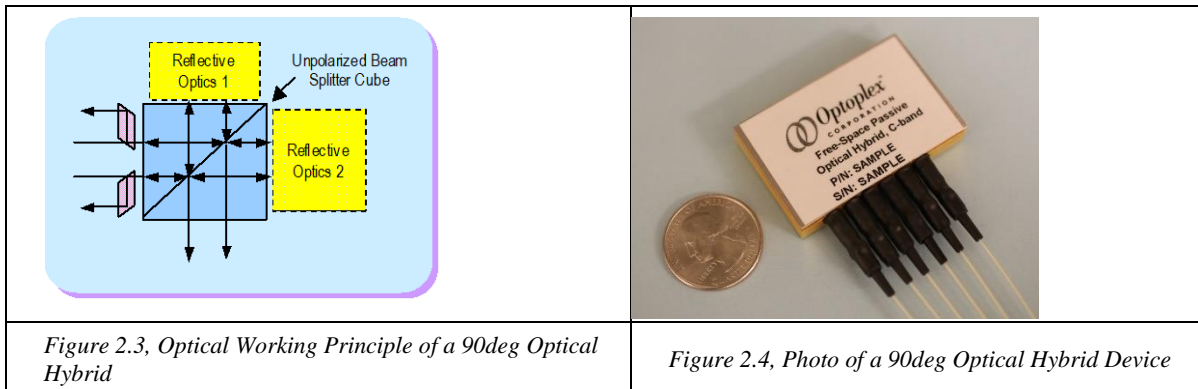
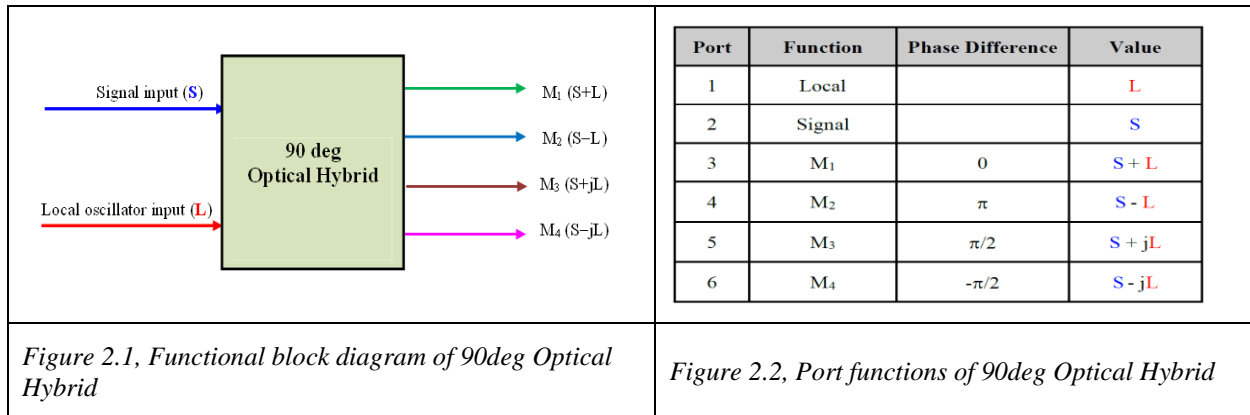

2.2 Balanced Detection

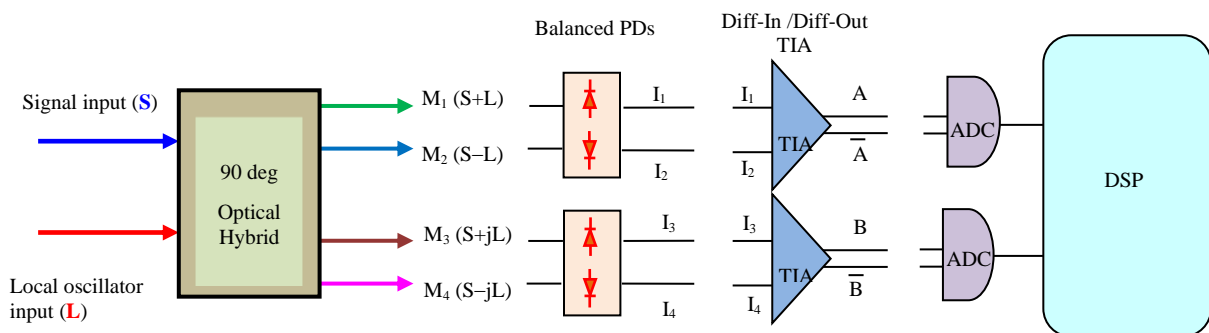

Figure 2.5, 90deg Optical Hybrid in coherent detection

Assuming the phase different between S and L is ϕ , with balanced detection by a pair of balanced photodiodes, the four outputs (intensity) from the balanced PDs are

$$I_1 = L^2 + S^2 + 2LS \cos(\phi)$$

$$I_2 = L^2 + S^2 - 2LS \cos(\phi)$$

$$I_3 = L^2 + S^2 + 2LS \sin(\phi)$$

$$I_4 = L^2 + S^2 - 2LS \sin(\phi)$$

With differential-in TIA, the output from the TIAs are

$$A = 4LS \cos(\phi)$$

$$B = 4LS \sin(\phi)$$

A and B will be processed by a DSP (after ADC), the phase difference, ϕ , can be extracted from

$$C = B / A = \tan(\phi)$$

$$\phi = \arctan(C)$$

Another way of the processing the data is to plot A^2 as “X” and B^2 as “Y”, you will get a circle – its diameter will present the amplitude of the signal.

$$A^2 + B^2 = (4LS)^2 \cos^2(\phi) + (4LS)^2 \sin^2(\phi) = (4LS)^2$$

Provided that L is known, then you will be able to calculate the signal’s amplitude “S” from above.

2.3 Performance Specifications of 90deg Optical Hybrid

Table 2.1, Optical Performance Specifications of 90deg Optical Hybrid

Parameter		Unit	Specification	Note
Wavelength Range	C-Band	nm	1527 ~ 1567	
	L-Band	nm	1570 ~ 1610	
	C+L Band	nm	1527 ~ 1610	
	O-Band	nm	1310 +/-20	
	1064nm	nm	1064 +/- 15	
Phase Difference ¹ (between M ₁ , M ₂ and M ₃ , M ₄)		deg	90 ± 10, or 90 ± 5	Table 2.2 in Section 2.4
Insertion Loss ¹ (without connector)	S→M _i	dB	< 8.5	
	L→M _i	dB	< 8.5	
Insertion Loss Difference ¹	S→M ₁ and S→M ₂	dB	< 0.7	
	S→M ₃ and S→M ₄	dB	< 0.7	
	L→M ₁ and S→M ₂	dB	< 0.7	
	L→M ₃ and S→M ₄	dB	< 0.7	
	Between all other ports	dB	< 1	
Optical Return Loss		dB	> 27	
Optical Path Difference (skew, between M ₁ and M ₂ and between M ₃ and M ₄)		ps	< 5	
Optical Path Difference (skew, between any other two outputs)		ps	< 5	
Fiber Type	Signal Input	-	SMF or PMF	Table 2.2 in Section 2.4
	Local Input			

	Outputs		SMF or PMF	
Fiber Pigtail Length		mm	1000 ± 100	
Connector Type		-	FC/APC	
PM Fiber and Connector Alignment		-	Slow Axis aligned to the key	Applicable when PMF is used. <i>Table 2.2 in Section 2.4</i>
S- and L-Input PM Fiber Alignment		-	≤ 5 between the two Fast Axes	
PER		dB	> 16	
Max. Input Optical Power		mW	300	
Operating Temperature		°C	0 ~ 65	
Storage Temperature		°C	-40 ~ 85	
Dimension (L×W×H) ²		mm	48 × 31 × 8.3	

Notes:

1. Over the stated spectral and operating temperature ranges and all polarization states.
2. Premium grade with Phase Error 90 +/-5 deg available. Contact Optoplex for details.
3. Subject to change, not including collimator sleeves extending from the two adjacent sides by 21 mm.
4. Standard design with SMF for all-ports. Other options
5. Standard connector, FC/APC. Other types available. See ordering information.

2.3 Mechanical Dimension

2.3.1, Mechanical Drawing

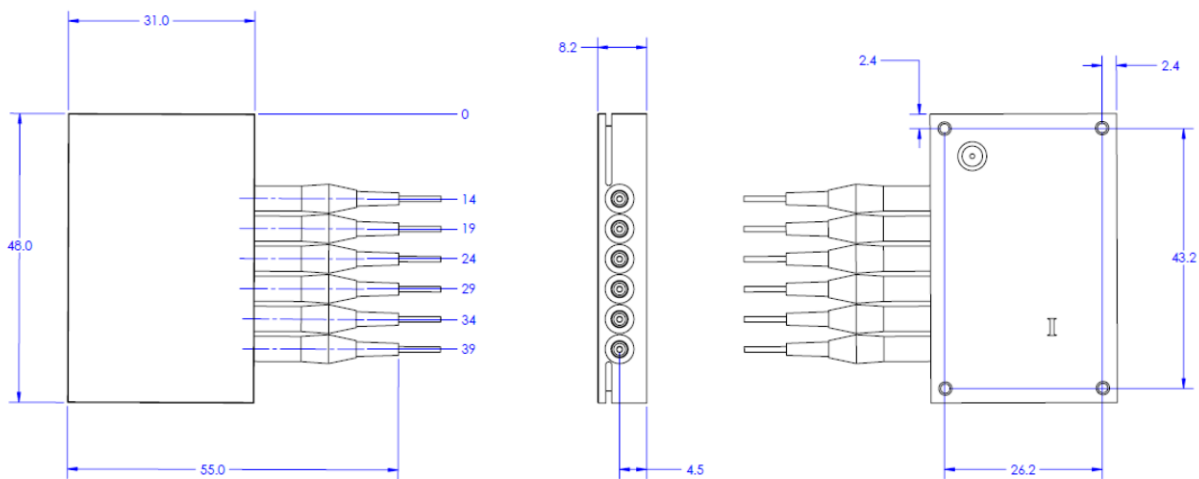

Figure 3.1, Mechanical Drawing of 90deg Optical Hybrid

2.3.2, Port Assignment

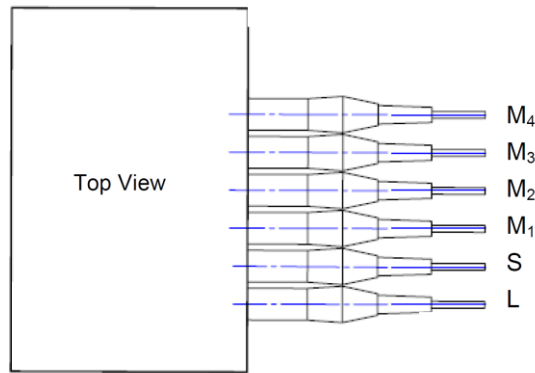

Figure 3.2, Port Assignment of 90deg Optical Hybrid

2.4 Typical Part Numbers of 90deg Optical Hybrids

Table 2.2, List of Part Numbers of 90deg Optical Hybrids

	Products	MPN	Wavelength	Fiber-Type		
				Signal-Input	Lo- Input	Outputs
C-Band	90-degree Optical Hybrid, C-Band, SMF for All Ports, Phase 90±10°	HB-C0AFAS002	C-Band	SMF	SMF	SMF
	90-degree Optical Hybrid, C-Band, SMF for All Ports, Phase 90±5°	HB-C0AFAS013	C-Band	SMF	SMF	SMF
	90-degree Optical Hybrid, C-Band, PMF for Input Ports (both Signal- and Lo-), SMF for All Output Ports, Phase 90±10°	HB-C0AFAC016	C-Band	PMF	PMF	SMF
	90-degree Optical Hybrid, C-Band, PMF for Input Ports (both Signal- and Lo-), SMF for All Output Ports, Phase 90±5°	HB-C0AFAC057	C-Band	PMF	PMF	SMF
	90-degree Optical Hybrid, C-Band, PMF for All Input and Output Ports, Phase 90±10°	HB-C0AFAC055	C-Band	PMF	PMF	PMF
	90-degree Optical Hybrid, C-Band, PMF for All Input and Output Ports, Phase 90±5°	HB-C0AFAS066	C-Band	PMF	PMF	PMF
L-Band	90-degree Optical Hybrid, L-Band, SMF for All Ports, Phase 90±10°	HB-L0AFAS094	L-Band	SMF	SMF	SMF
	90-degree Optical Hybrid, L-Band, SMF for All Ports, Phase 90±5°	HB-L1AFAS094	L-Band	SMF	SMF	SMF
	90-degree Optical Hybrid, L-Band, PMF for Inputs; PMF for Outputs, Phase 90±10°	HB-L0AFAP095	L-Band	PMF	PMF	PMF

	90-degree Optical Hybrid, L-Band, PMF for Inputs; PMF for Outputs, Phase 90±5°	HB-L1AFAP095	L-Band	PMF	PMF	PMF
	90-degree Optical Hybrid, L-Band, PMF for Inputs; SMF for Outputs, Phase 90±10°	HB-L0AFAX096	L-Band	PMF	PMF	SMF
	90-degree Optical Hybrid, L-Band, PMF for Inputs; SMF for Outputs, Phase 90±5°	HB-L1AFAX096	L-Band	PMF	PMF	SMF
C+L Band	90-degree Optical Hybrid, C+L Band, SMF for All Ports, Phase 90±10°	HB-T0AFAS101	C+L Band	SMF	SMF	SMF
	90-degree Optical Hybrid, C+L Band, SMF for All Ports, Phase 90±5°	HB-T1AFAS101	C+L Band	SMF	SMF	SMF
	90-degree Optical Hybrid, C+L Band, PMF for All Ports, Phase 90±10°	HB-T0AFAP102	C+L Band	PMF	PMF	PMF
	90-degree Optical Hybrid, C+L Band, PMF for All Ports, Phase 90±5°	HB-T1AFAP102	C+L Band	PMF	PMF	PMF
	90-degree Optical Hybrid, C+L Band, PMF for Inputs, SMF for Outputs, Phase 90±10°	HB-T0AFAX103	C+L Band	PMF	PMF	SMF
	90-degree Optical Hybrid, C+L Band, PMF for Inputs, SMF for Outputs, Phase 90±5°	HB-T1AFAX103	C+L Band	PMF	PMF	SMF
O-Band	90-degree Optical Hybrid, O-Band, SMF for All Ports, Phase 90±10°	HB-Q0AFAS1310	O-Band	SMF	SMF	SMF
	90-degree Optical Hybrid, O-Band, SMF for All Ports, Phase 90±5°	HB-Q1AFAS1310	O-Band	SMF	SMF	SMF
	90-degree Optical Hybrid, O-Band, PMF for Inputs; SMF for Outputs. Phase 90±10°	HB-Q0AFAX1310	O-Band	PMF	PMF	SMF
	90-degree Optical Hybrid, O-Band, PMF for Inputs; SMF for Outputs. Phase 90±5°	HB-Q1AFAX1310	O-Band	PMF	PMF	SMF
	90-degree Optical Hybrid, O-Band, PMF for All ports. Phase 90±10°	HB-Q0AFAP1310	O-Band	PMF	PMF	PMF
	90-degree Optical Hybrid, O-Band, PMF for All ports. Phase 90±5°	HB-Q1AFAP1310	O-Band	PMF	PMF	PMF
1064nm	90-degree Optical Hybrid, 1064+/-5nm, HI1060 SMF for All Ports, Phase 90±10°	HB-A0AFAS1064	1064nm	HI-1064	HI-1064	HI-1064
	90-degree Optical Hybrid, 1064+/-5nm, HI1060 SMF for All Ports, Phase 90±5°	HB-A1AFAS1064	1064nm	HI-1064	HI-1064	HI-1064
	90-degree Optical Hybrid, 1064+/-5nm, PM Fiber (PM980 Panda) Inputs, HI1060 SMF for Outputs, Phase 90±10°	HB-A0AFAX1064	1064nm	PM980	PM980	HI-1064
	90-degree Optical Hybrid, 1064+/-5nm, PM Fiber (PM980 Panda) Inputs, HI1060 SMF for Outputs, Phase 90±5°	HB-A1AFAX1064	1064nm	PM980	PM980	HI-1064

	90-degree Optical Hybrid, 1064+/-5nm, PM Fiber (PM980 Panda) for all Input and Output ports, Phase 90±10°	HB-A0AFAP1064	1064nm	PM980	PM980	PM980
	90-degree Optical Hybrid, 1064+/-5nm, PM Fiber (PM980 Panda) for all Input and Output ports, Phase 90±5°	HB-A1AFAP1064	1064nm	PM980	PM980	PM980

Notes:

- 1) By default, the connector is FC/APC. Other connector types are available, such as FC/UPC, LC/UPC, LC/APC, SC/UPC, ..., etc.

90deg Optical Hybrid Device with Fiber Pigtailed Inputs and Outputs

- Device Dimension: 48 x 31 x 8.5mm
(Excluding the sleeves and the optical collimators)
- Weight: 96 grams

3. 90deg Optical Hybrid with Single-ended PD Outputs

The optical performance of the 90deg optical hybrid is same as those described in previous sections, except for the output collimators are replaced by single-ended photodetectors.

3.1 Functional Block Diagram

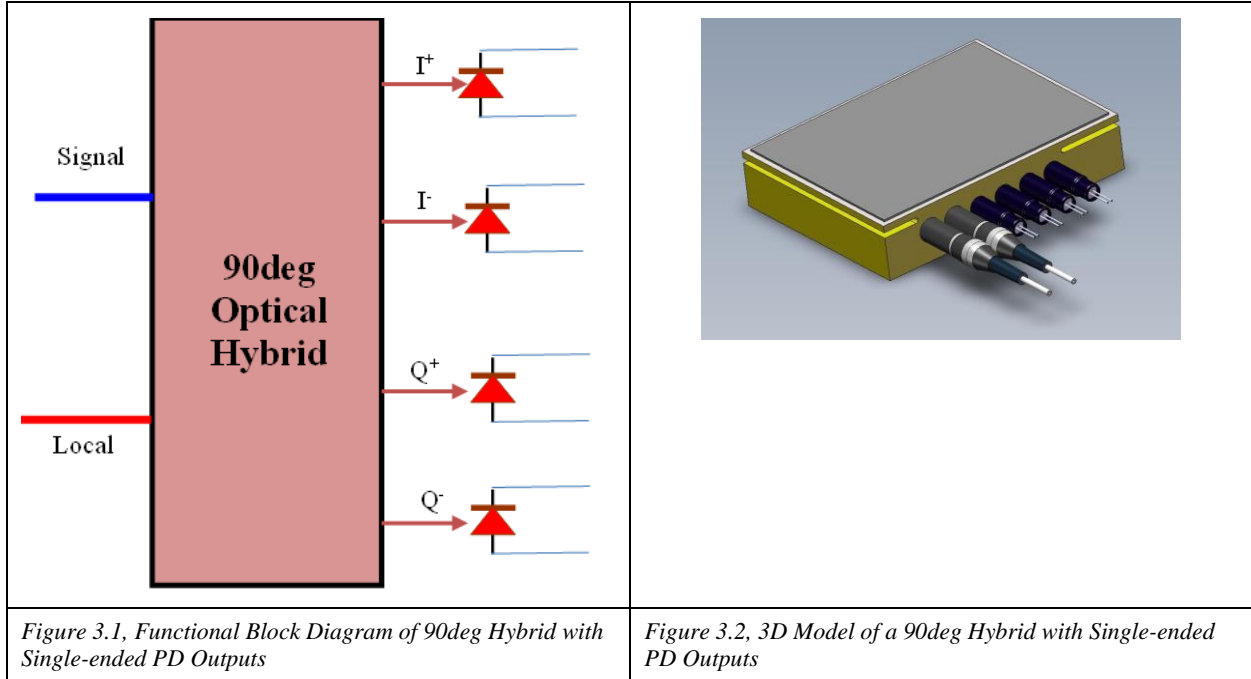

3.2 Mechanical Drawing

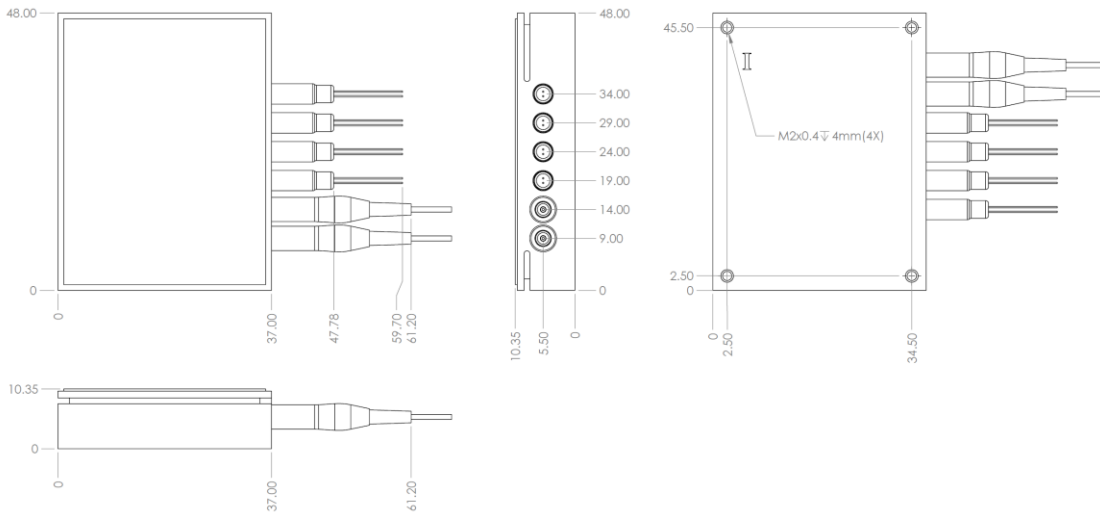

Figure 3.3, Mechanical Drawings of a 90deg Hybrid with Single-ended PD Outputs

3.3 Photodiode Properties

Currently, there are three options the bandwidths of the Photodiodes: 1GHz, 3GHzx and 7GHz.

3.3.1 PDs with 0.6GHz BW

Table 3.1, Optical Properties of PD with 0.6GHz BW

Parameter	Symbol	Test Conditions	Min.	Typ.	Max.	Unit
Active Diameter	D	—	—	300	—	μm
Bandwidth	BW	$V_R=5V$	—	0.6	—	GHz
Responsivity	@1310nm	R	$V_R=5V$	0.8	—	A/W
	@1550nm	R	$V_R=5V$	0.9	—	A/W
Dark Current (@RT)	ID	$V_R=5V$	—	—	1	nA
Chip Capacitance	C_{chip}	$V_R=5V, f=1MHz$	—	—	6	pF
Optical Spectrum Response Range	λ	—	1100	—	1650	nm
Operating Voltage (Reverse Biased)	V	—	—	-5	—	V

3.3.2 PDs with 3GHz BW

Table 3.2, Optical Properties of PD with 3GHz BW

Parameter	Symbol	Test Conditions	Min.	Typ.	Max.	Unit	
Active Diameter	D	—	—	60	—	μm	
Bandwidth	BW	$V_R=5V$	3.0	—	—	GHz	
Responsivity	@1310nm	R	$V_R=5V$	0.8	0.85	—	A/W
	@1550nm	R	$V_R=5V$	0.9	0.95	—	A/W
Dark Current (@RT)	ID	$V_R=5V$	—	0.2	1	nA	
Chip Capacitance	C_{chip}	$V_R=5V, f=1MHz$	—	0.45	0.5	pF	
Optical Spectrum Response Range	λ	—	1100	—	1650	nm	

Operating Voltage (Reverse Biased)	V	—	—	-5	—	V
------------------------------------	---	---	---	----	---	---

3.3.3 PDs with 7GHz BW

Table 3.3, Optical Properties of PD with 7GHz BW

Parameter	Symbol	Test Conditions	Min.	Typ.	Max.	Unit	
Active Diameter	D	—	—	45	—	μm	
Bandwidth	BW	$V_R=5V$	7	10	—	GHz	
Responsivity	@1310nm	R	$V_R=5V$	0.75	0.8	—	A/W
	@1550nm	R	$V_R=5V$	0.8	0.85	—	A/W
Dark Current	ID	$V_R=5V$	—	1	5	nA	
Chip Capacitance	C_{chip}	$V_R=5V, f=1MHz$	—	0.11	0.13	pF	
Optical Spectrum Response Range	λ	—	1100	—	1650	nm	
Operating Voltage	V	—	—	-5	—	V	

3.4 Part Numbers and Ordering Information

Table 3.4, List of Part Numbers of 90deg Hybrid with Single-ended PD Outputs

Wavelength Band	Part Number	I/Q Phase (Deg)	Type of Fiber		Photodiode Bandwidth (GHz)	Note
			Signal-Port	Local-Port		
C-Band	RX-AC0600S101	90 +/- 10	SMF	SMF	0.6	
	RX-AC0600P101	90 +/- 10	PMF	PMF	0.6	
	RX-AC5000S102	90 +/- 10	SMF	SMF	5.0	
	RX-AC5000P102	90 +/- 10	PMF	PMF	5.0	
	RX-AC3000S103	90 +/- 10	SMF	SMF	5.0	
	RX-AC3000P103	90 +/- 10	PMF	PMF	5.0	
L-Band	RX-AL0600S111	90 +/- 10	SMF	SMF	0.6	
	RX-AL0600P111	90 +/- 10	PMF	PMF	0.6	

	RX-AL5000S112	90 +/- 10	SMF	SMF	5.0	
	RX-AL5000P112	90 +/- 10	PMF	PMF	5.0	
	RX-AL3000S113	90 +/- 10	SMF	SMF	5.0	
	RX-AL3000P113	90 +/- 10	PMF	PMF	5.0	
C+L Band	RX-AT0600S121	90 +/- 10	SMF	SMF	0.6	
	RX-AT0600P121	90 +/- 10	PMF	PMF	0.6	
	RX-AT5000S122	90 +/- 10	SMF	SMF	5.0	
	RX-AT5000P122	90 +/- 10	PMF	PMF	5.0	
	RX-AT3000S123	90 +/- 10	SMF	SMF	5.0	
	RX-AT3000P123	90 +/- 10	PMF	PMF	5.0	
O - Band	RX-AQ0600S131	90 +/- 10	SMF	SMF	0.6	
	RX-AQ0600P131	90 +/- 10	PMF	PMF	0.6	
	RX-AQ5000S132	90 +/- 10	SMF	SMF	5.0	
	RX-AQ5000P132	90 +/- 10	PMF	PMF	5.0	
	RX-AQ3000S133	90 +/- 10	SMF	SMF	5.0	
	RX-AQ3000P133	90 +/- 10	PMF	PMF	5.0	

Type of Fibers

- SMF: Corning SMF-28e+ or equivalent for O, C-, L- and C+L Bands
- PMF: Panda type PMF will be used. For 1550nm, using PM-1550; for 1310nm, using PM-1310

4. 90deg Optical Hybrid integrated with Balanced Receivers

4.1 Introduction

The functional block diagram and the product photo of 90deg optical hybrid integrated receivers are shown below in Figure 4.1 and Figure 4.2.

The 90deg optical hybrids are described in previous Section-2. The customer has a choice to choose Single-Mode Fiber (SMF) and Polarization-Maintaining Fiber (PMF) when ordering the product.

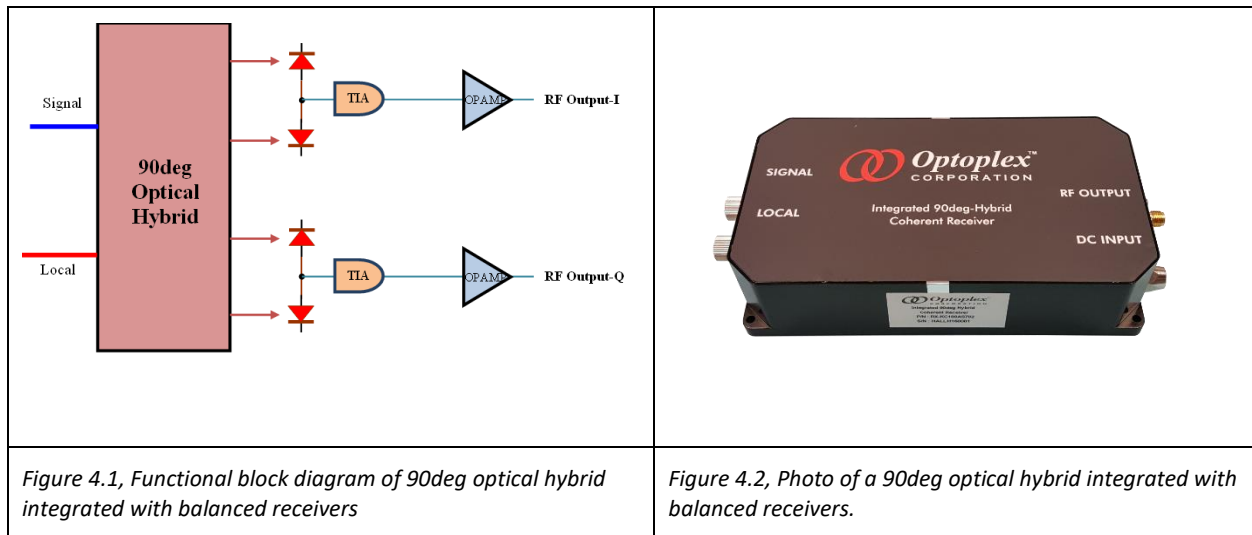

As for the balanced receivers, there are difference bandwidths from 15MHz, 100MHz, 200MHz, 350MHz, 400MHz, 700MHz, 1.2GHz to 1.6GHz. Higher bandwidth versions (3GHz and 7GHz) will be available soon. Contact Optoplex for details.

There are two options for the RF outputs: DC-coupled or AC-coupled RF outputs for the customer to choose from.

(Note for 700MHz, 1.2GHz and 1.6GHz, only AC-coupled output available)

4.2 Max Absolute Ratings

Table 4.2, Max Absolute Ratings

No	Parameter	Symbol	Unit	Conditions	Ratings		Notes
					Min	Max	
1	Input Optical Power	P_{in_Max}	mW		-	20	See Note-a in 6.3) below
2	Operating Temperature	T_c	°C		-5	+70	
3	Operating Humidity	-	%RH	$T_c = +65^{\circ}C$, Non-condensing	5	85	

4	Storage Temperature	T_{stg}	$^{\circ}C$		-40	+85	
5	Storage Humidity	-	%RH	$T_c = +85^{\circ}C$, Non-condensing	5	85	

4.3 Operating Conditions

Table 4.3, Operating Conditions

No	Parameter	Symbol	Unit	Conditions	Ratings			Notes
					Min	Typ.	Max	
1	Input Optical Power	P_{in_Max}	mW		-		10	a)
2	Operating Temperature	T_c	$^{\circ}C$		-5		+65	
3	Operating Humidity, Relative, 40 $^{\circ}C$ non-condensing	-	%RH		5		85	
4	Storage Temperature	T_{stg}	$^{\circ}C$		-40		+85	
5	Storage Humidity	-	%RH		5		85	

Notes:

- a) The max input optical power is limited by the Photodiodes and Amplifiers. Higher input will saturate the photodiodes and the amplifiers.

4.4, Balanced Receiver Specifications

4.4.1 General Requirements

Table 4.4.1, General Requirements

#	Parameter	Unit	Specification	Note
1	Photodetector	/	InGaAs	
2	Wavelength Range	nm	1250 ~ 1650	
3	Responsivity of the Photodiodes	A/W	>0.9 @1550nm ~0.85 @1310nm	
4	Max Optical Input Power	mW	10	
5	Power Supply, Voltage	V	+/-12	A +/-12VDC power supply will be supplied as an optional item
6	Power Supply, Current	mA	200	
7	Electrical Output Interface	/	SMA	

4.4.2 Electrical Performance Specifications of Balanced Receivers

Table 4.4.2, Electrical Specifications of the Balanced Receivers

#	Parameter	Unit	15MHz	100MHz	200MHz	400MHz	700MHz	1.2GHz	1.6GHz
1	RF Output Bandwidth (3dB): DC ~ xxx	MHz	15	100	200	400	700	1200	1600 ¹⁾
2	Common Mode Rejection Ratio (CMRR) ²⁾	dB	20	20	20	20	20	20	20
3	Transimpedance Gain	V/A	25.5x10 ³	25x10 ³	15x10 ³	5x10 ³	5x10 ³	14x10 ³	16x10 ³
4	Conversion Gain RF Output	V/W	25.5x10 ³	25x10 ³	15x10 ³	4.5x10 ³	4.5x10 ³	12x10 ³	14.4x10 ³
5	NEP (DC - 10MHz)	pW/\sqrt{Hz}	3.3	3.8	6.0	8.0	9.0	9.3	9.5
6	Integrated Noise (DC - 100MHz)	nV _{RMS}	14	65	130	140	160	180	200
7	Overall Output Voltage Noise	mV _{RMS}	0.4	2.2	2.3	2.5	5	9	10
8	RF Output Impedance	Ω	50	50	50	50	50	50	50
9	RF Output Voltage Swing	V	+/-3.6	+/-3.6	+/-3.8	+/-3.8	+/-3.6	+/-3.6	+/-3.6
10	DC Offset RF Output ³⁾	mV	+/-3	+/-3	+/-5	+/-5	+/-8	+/-8	+/-10

Notes:

- 1) Typical bandwidth 1.6GHz. Can be optimized ~2.0GHz Max when needed
- 2) CMRR > 20dBm, typical ~ 25dB. Special design with high CMRR available, contact Optoplex for details.
- 3) When configured as AC-coupled output.

4.5, List of Part Numbers of 90deg Optical Hybrid Integrated Receivers

Table 4.5, List of Part Numbers of 90deg Hybrid Integrated Receivers

BW of the Balanced Receivers	Fiber Types of Input Ports		Part Numbers			
	Signal-	Local-	C-Band P/Ns	C+L Band P/Ns	O-Band P/Ns	1064nm P/Ns
15MHz	PMF	PMF	RX-KC0015P817xx	RX-KT0100P867xx	RX-KQ0015P837xx	RX-KA0015P897xx
15MHz	SMF	SMF	RX-KC0015S818xx	RX-KT0100S868xx	RX-KQ0015S838xx	RX-KA0015S898xx
100MHz	PMF	PMF	RX-KC0100P801xx	RX-KT0100P851xx	RX-KQ0100P831xx	RX-KA0100P881xx
100MHz	SMF	SMF	RX-KC0100S802xx	RX-KT0100S852xx	RX-KQ0100S832xx	RX-KA0100S882xx
200MHz	PMF	PMF	RX-KC0200P803xx	RX-KT0200P853xx	RX-KQ0200P833xx	RX-KA0200P883xx
200MHz	SMF	SMF	RX-KC0200S804xx	RX-KT0200S854xx	RX-KQ0200S834xx	RX-KA0200S884xx
350MHz	PMF	PMF	RX-KC0350P805xx	RX-KT0350P855xx	RX-KQ0350P835xx	RX-KA0350P885xx
350MHz	SMF	SMF	RX-KC0350S806xx	RX-KT0350S856xx	RX-KQ0350S836xx	RX-KA0350S886xx
400MHz	PMF	PMF	RX-KC0400P807xx	RX-KT0400P857xx	RX-KQ0400P837xx	RX-KA0400P887xx
400MHz	SMF	SMF	RX-KC0400S808xx	RX-KT0400S858xx	RX-KQ0400S838xx	RX-KA0400S888xx
700MHz	PMF	PMF	RX-KC0700P809xx	RX-KT0700P859xx	RX-KQ0700P839xx	RX-KA0700P889xx
700MHz	SMF	SMF	RX-KC0700S810xx	RX-KT0700S860xx	RX-KQ0700S840xx	RX-KC0700S890xx
1.2GHz	PMF	PMF	RX-KC1200P811AC	RX-KT1200P861AC	RX-KQ1200P841AC	RX-KA1200P891AC
1.2GHz	SMF	SMF	RX-KC1200S812AC	RX-KT1200S862AC	RX-KQ1200S842AC	RX-KA1200S892AC
1.6GHz	PMF	PMF	RX-KC1600P815AC	RX-KC1600P815AC	RX-KQ1600P845AC	RX-KA1600P895AC
1.6GHz	SMF	SMF	RX-KC1600S816AC	RX-KT1600S866AC	RX-KQ1600S846AC	RX-KA1600S896AC

Notes:

1) Part Number: RX - KCnnnnYnnnXX

XX = DC, DC coupled RF Output

XX = AC, AC coupled RF Output

Y = S, SM Fiber for Optical Inputs

Y = P, PM Fiber for Optical Inputs

For 700MHz, 1.2GHz, and 1.6GHz, only AC-coupled output available

- 2) By default, the optical connector of the input ports is FC/APC

Other types of connectors available

- 3) By default, the 90deg phase is 90+/-10deg.

Premium grade of 90+/-5deg possible at extra cost. Contact Optoplex for details

90deg Optical Hybrid Integrated with Balanced Receivers

- Module Dimension: 150 x 82 x 36 mm
- Weight: 460 grams

4.6, Mechanical Drawings of 90deg Optical Hybrid Integrated Receiver

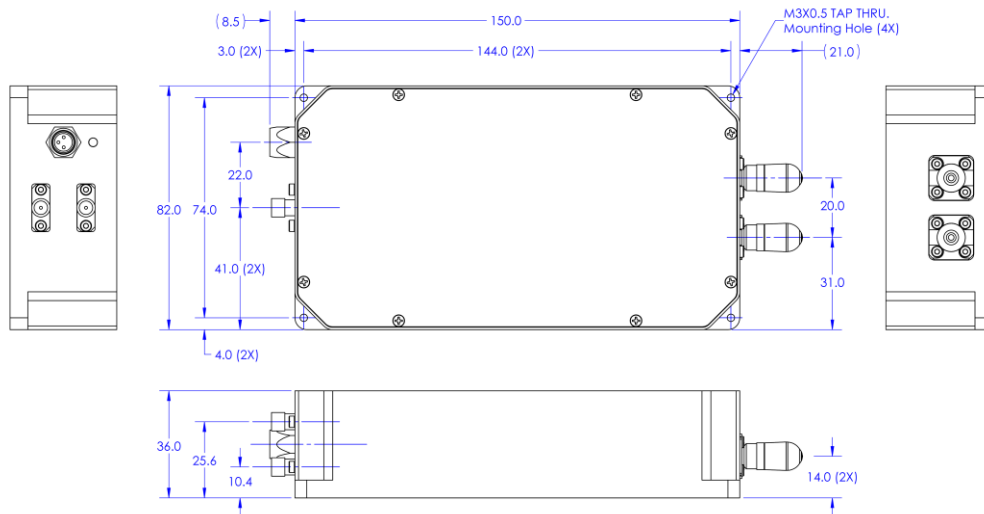

Figure 4.6.1, Mechanical drawing of the integrated 90deg hybrid with balanced receiver

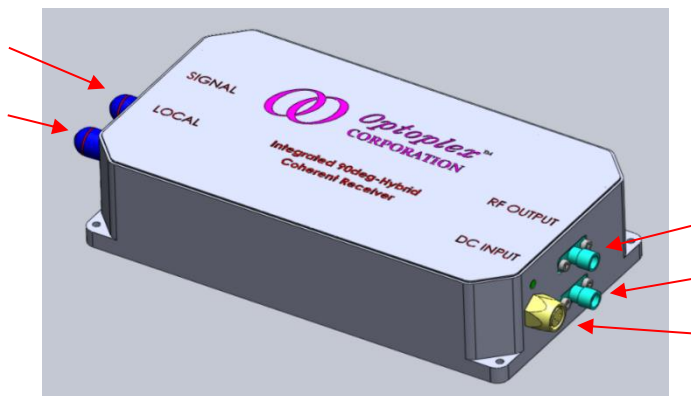

Figure 4.6.2, Input and Output Port Labelling of 90deg Hybrid with Balanced Receivers

5. Phase-Tunable 90deg Optical Hybrids

5.1 Introduction

The phase-tunable 90deg optical hybrid is based on the same platform of the standard 90deg optical hybrid as described in Section 2, by adding a phase-tuning mechanism inside the device.

The optical performance of the phase-tunable 90deg hybrid is same as the standard 90deg optical hybrid as described in Section. Besides, the user is able to apply a tuning voltage to tune the device to achieve much better 90deg I/Q phase difference, i.e., to be able to get 90+/-0.5deg in the designated working wavelength range.

5.2. Physical Properties

5.2.1, Device Dimension

Table 5.2.1, Device Dimensions

Parameter	unit	Spec
Dimension: L x W x H	mm	48 x 31 x 10

5.2.2, Mechanical Drawing

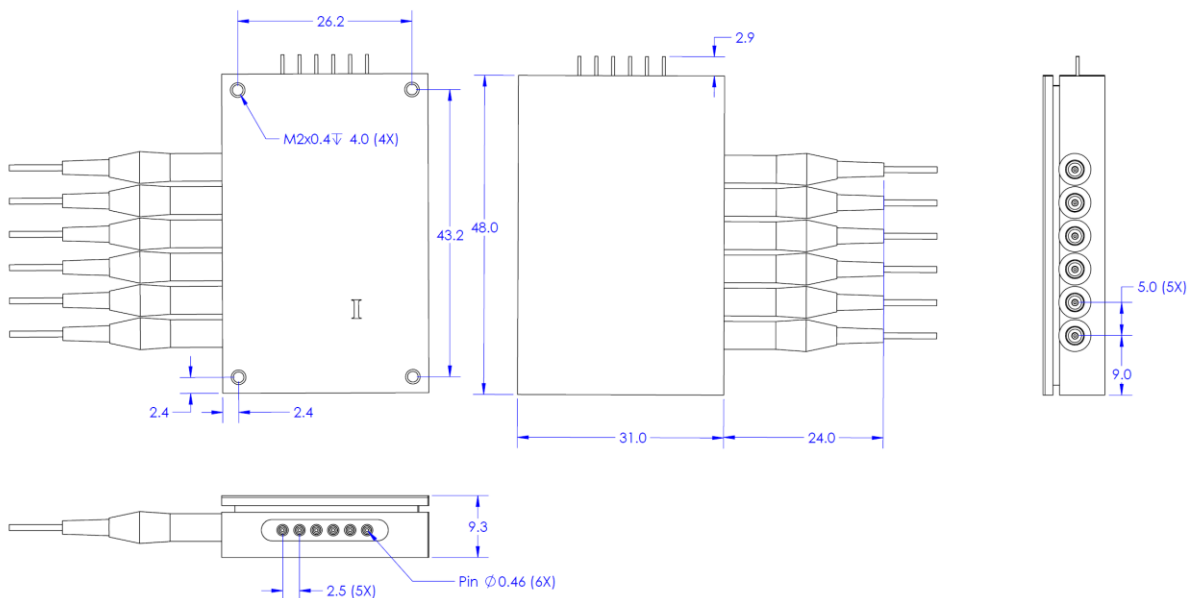

Figure 5.2.1, Mechanical Drawing of the Device

5.3 Phase-Tuning Performance

The product is built with initial performance of the I/Q phase difference: $\leq 90 \pm 5 \text{deg}$.

The phase-tuning is for fine-tuning to achieve precise 90deg I/Q Phase Difference under below limited wavelength and temperature ranges.

Table 5.2, Phase Tuning Performance

#	Parameter	Unit	Min	Typ.	Max	Note
1	Operating Wavelength Range ¹⁾	nm	1540		1560	
2	Operating Temperature Range ²⁾	°C	20		35	
3	I-Chan Phase Tuning Voltage, V_{PI} ³⁾	V	0		1.5	
4	Q-Chan Phase Tuning Voltage, V_{PQ} ³⁾	V	0		1.5	
5	I/Q Phase Difference, under optimized Phase Tuning ⁴⁾	deg	89.5	90	90.5	90 ± 0.5 ⁵⁾

Notes

- 1) Wider wavelength range as set in 5.3.01 (whole C-Band) may still work. However, due to the material's dispersion property, the optical performance (such as phase, insertion loss) more or less has some wavelength dependence. Narrower working wavelength will result-in more accurate (or more uniform performance across the designated wavelength range).
- 2) Similar to wavelength dependence, the device also has slight temperature dependency (although it is designed with athermal) due to the material's Coefficient of Thermal Expansion (CTE) property. Limiting the working temperature in a narrow range will make the phase tuning easier.
- 3) With current design, 1.2VDC Tuning Voltage will be able to tune the phase in about 5deg. Increasing the tuning voltage will be able to get large phase tuning range. It will take longer time to achieve thermal equilibrium. Due to thermal stability concern, it is recommended to limit the max tuning voltage $< 2.0 \text{ VDC}$.
- 4) Depending on the operating wavelength and temperature ranges, more accurate I/Q phase (90deg) control may be achievable if accurate and stable tuning voltage is applied. In some case, an active control of the Tuning Voltage with a closed-loop feedback control may be required.
- 5) Either for I^+/Q^+ or I^-/Q^- phase difference. If I^+/Q^+ is optimized by the phase tuning, ideally, I^-/Q^- should be optimized as well. However, due to manufacturing tolerance, there might be 0.5~ 1.0deg MAX phase difference between I^+/Q^+ and I^-/Q^- .

5.4, Phase Tuning Pin Definition

5.4.1 Electrical Control Pin (for Phase-Tuning) Assignments

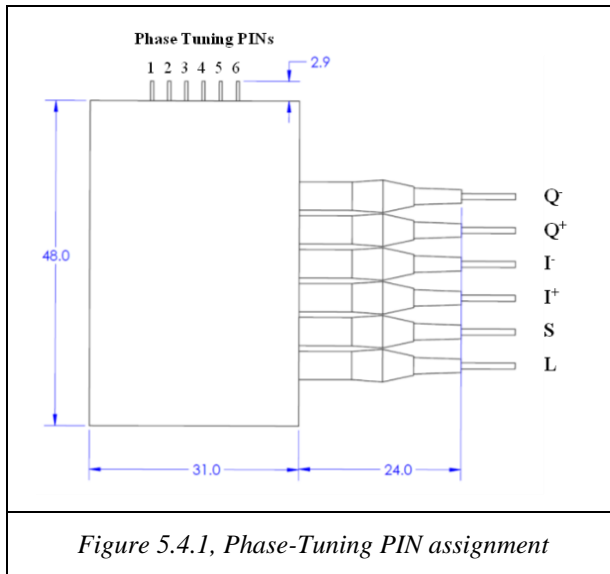

Figure 5.4.1, Phase-Tuning PIN assignment

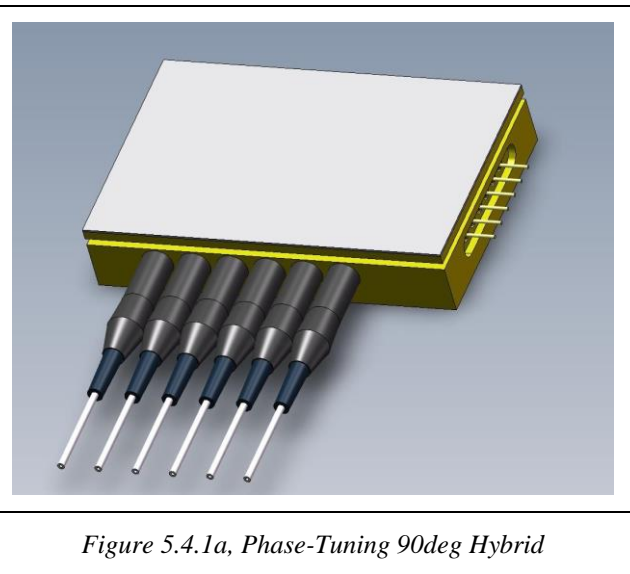

Figure 5.4.1a, Phase-Tuning 90deg Hybrid

5.4.2 Function Definitions of the Phase-Tuning PINs

Table 5.4, Pin Definition

#	Pin #	Symbol	Function	Note
1	1	V _{PI} (+)	Tuning Voltage for I – Channel, 0 ~ 1.5VDC	No polarity
2	2	V _{PI} (-)		
3	3	V _{PQ} (+)	Tuning Voltage for Q – Channel, 0 ~ 1.5VDC	No polarity
4	4	V _{PQ} (-)		
5	5	R _{TH} (+)	Thermistor (+)	
6	6	R _{TH} (-)	Thermistor (-)	

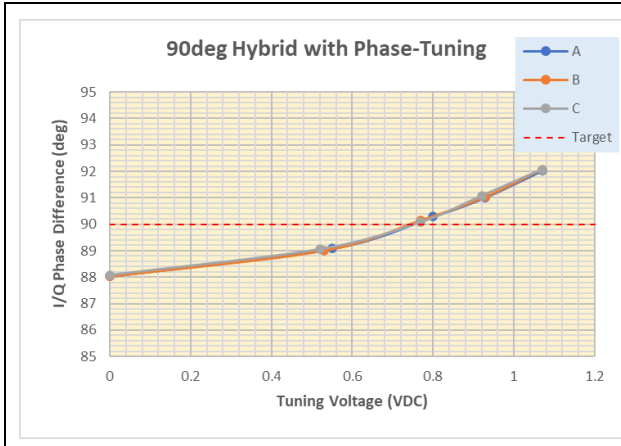

Figure 5.4.2, I/Q Phase vs Tuning Voltage

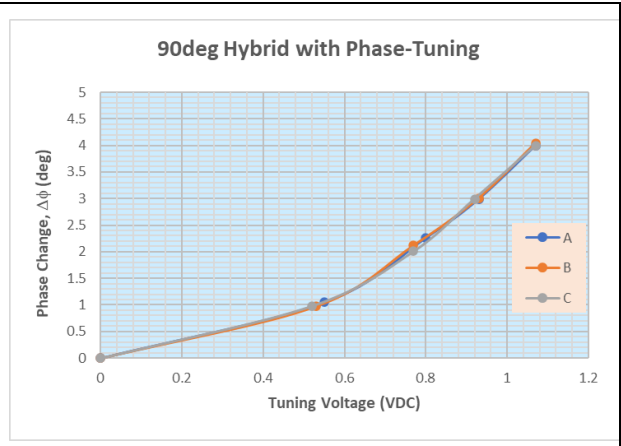

Figure 5.4.3, I/Q Phase Change vs Tuning Voltage

The charts in [Figure 5.4.2](#) and [Figure 5.4.3](#) were measured on device with static state of I/Q phase = 88deg. A: 1520 ~ 1560nm; B: 1530 ~ 1550nm; C: 1540 ~ 1550nm. They are for references ONLY.

Phase-Tuning:

- 1) When I/Q Phase < 90deg; Apply voltage to Q-Channel and Tune Q-Ch only. Leave I-Ch unbiased (V=0V);
- 2) When I/Q Phase > 90deg; Apply voltage to I-Channel and Tune I-Ch only. Leave Q-Ch unbiased (V=0V);

Note:

Regardless I/Q >90 or <90, theoretically, applying voltages to both I- and Q-channels, it is still possible to achieve I/Q ≈ 90deg. However, the voltage to one channel might be too high and cause thermal stability issue. It is NOT recommended to use this control approach.

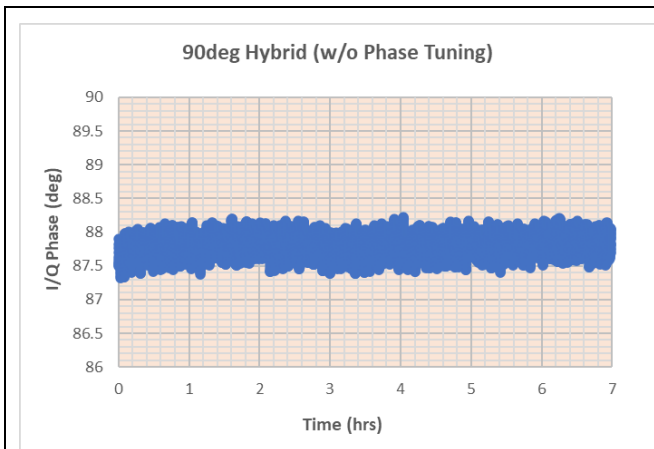

Figure 5.4.4, I/Q Phase of a 90deg Hybrid (w/o Phase-Tuning)

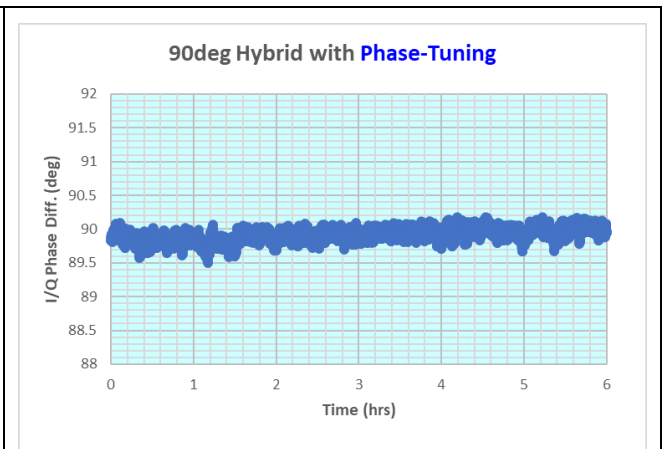

Figure 5.4.5, I/Q Phase of a 90deg Hybrid with Phase-Tunable (Optimized)

5.5, Popular Part Numbers of Phase-Tunable 90deg Optical Hybrids

Table 5.5. Part Numbers vs Fiber Types

#	Products	MPN	Wavelength	Fiber-Type		
				Signal-Input	Lo- Input	Outputs
1	90-degree Optical Hybrid, C-Band, SMF for Input Ports (both Signal- and Lo-), SMF for All Output Ports, I/Q Phase Tunable	HB-C2AFAS501	C-Band	SMF	SMF	SMF
2	90-degree Optical Hybrid, C-Band, PMF for Input Ports (both Signal- and Lo-), SMF for All Output Ports, I/Q Phase Tunable	HB-C2AFAX502	C-Band	PMF	PMF	SMF
3	90-degree Optical Hybrid, C-Band, PMF for Input Ports (both Signal- and Lo-), PMF for All Output Ports, I/Q Phase Tunable	HB-C2AFAP503	C-Band	PMF	PMF	PMF
5	90-degree Optical Hybrid, L-Band, SMF for Input Ports (both Signal- and Lo-), SMF for All Output Ports, I/Q Phase Tunable	HB-L2AFAS511	L-Band	SMF	SMF	SMF
6	90-degree Optical Hybrid, L-Band, PMF for Input Ports (both Signal- and Lo-), SMF for All Output Ports, I/Q Phase Tunable	HB-L2AFAX512	L-Band	PMF	PMF	SMF
7	90-degree Optical Hybrid, L-Band, PMF for Input Ports (both Signal- and Lo-), PMF for All Output Ports, I/Q Phase Tunable	HB-L2AFAP513	L-Band	PMF	PMF	PMF
8	90-degree Optical Hybrid, C+L Band, SMF for Input Ports (both Signal- and Lo-), SMF for All Output Ports, I/Q Phase Tunable	HB-T2AFAS521	C+L Band	SMF	SMF	SMF
9	90-degree Optical Hybrid, C+L Band, PMF for Input Ports (both Signal- and Lo-), SMF for All Output Ports, I/Q Phase Tunable	HB-T2AFAX522	C+L Band	PMF	PMF	SMF
10	90-degree Optical Hybrid, C+L Band, PMF for Input Ports (both Signal- and Lo-), PMF for All Output Ports, I/Q Phase Tunable	HB-T2AFAP523	C+L Band	PMF	PMF	PMF
11	90-degree Optical Hybrid, O-Band (1310+/-20nm), SMF for Input Ports (both Signal- and Lo-), SMF for All Output Ports, I/Q Phase Tunable	HB-Q2AFAS531	1310+/-20	SMF	SMF	SMF
12	90-degree Optical Hybrid, O-Band (1310+/-20nm), PMF for Input Ports (both Signal- and Lo-), SMF for All Output Ports, I/Q Phase Tunable	HB-Q2AFAX532	1310+/-20	PMF	PMF	SMF
13	90-degree Optical Hybrid, O-Band (1310+/-20nm), PMF for Input Ports (both Signal- and Lo-), PMF for All Output Ports, I/Q Phase Tunable	HB-Q2AFAP533	1310+/-20	PMF	PMF	PMF

6. 2x8 DP-QPSK Coherent Mixer (aka Polarization-Diversified 90deg Hybrid)

The 2x8 DP-QPSK coherent mixer consists of two standard 90deg optical hybrids inside, each works on one polarization. In front of them (the two 90deg hybrids), there is one PBS at the Signal-path to split the signal into two, and similarly a beam splitter (BS) in the Local-path to split the local signal into two. See the functional diagram in Figure 6.1 below.

The 2x8 DP-QPSK coherent mixer is called as Polarization-Diversified 90deg Hybrid.

6.1. Functional Diagram

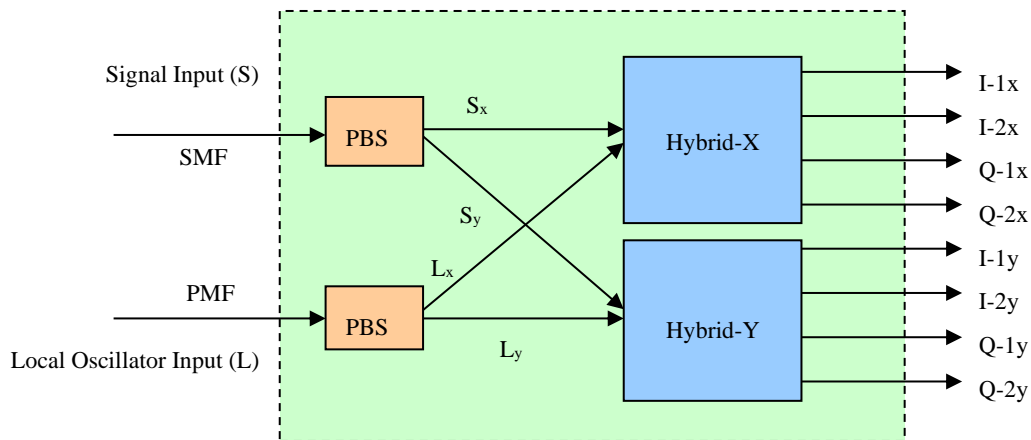

Figure 6.1, Functional Diagram of 2x8 DP-QPSK coherent mixer.

6.2. Port Definition

Table 6.2, Port Definition of 2x8 DP-QPSK Coherent Mixer

Port#	Function	Phase Difference	Polarization	Value	Note
1	Local			L	
2	Signal			S	
3	I-1x	0	x	$S_x + L_x$	
4	I-2x	π	x	$S_x - L_x$	
5	Q-1x	$\pi/2$	x	$S_x + jL_x$	
6	Q-2x	$3\pi/2$	x	$S_x - jL_x$	
7	I-1y	0	y	$S_y + L_y$	
8	I-2y	π	y	$S_y - L_y$	
9	Q-1y	$\pi/2$	y	$S_y + jL_y$	
10	Q-2y	$3\pi/2$	y	$S_y - jL_y$	

6.3. Specifications

Table 6.3 Performance Specifications

Parameter		Unit	Specification
Wavelength Range		<i>nm</i>	
Phase Difference ¹ (between I-1 _k and Q-1 _k ; and between I-2 _k and Q-2 _k), k=x or y		<i>degree</i>	90 ± 10
Insertion Loss ¹ (not including connector)	S (polarization scrambled) → Any of 8 Outputs	<i>dB</i>	9 ~ 12
	L (45° linear polarized) → Any of 8 Outputs	<i>dB</i>	9 ~ 12
Insertion Loss Uniformity ¹	Between S → I-1 _k and S → I-2 _k (k = x or y)	<i>dB</i>	< 0.7
	Between S → Q-1 _k and S → Q-2 _k (k = x or y)		< 0.7
	Between L → I-1 _k and L → I-2 _k (k = x or y)		< 0.7
	Between L → Q-1 _k and L → Q-2 _k (k = x or y)		< 0.7
	Among All Others	<i>dB</i>	< 1.5
Optical Return Loss		<i>dB</i>	> 27
Optical Path Difference ¹ (Skew, among S → Outputs)	Between I-1 _k and I-2 _k (k = x or y)	<i>ps</i>	< 1
	Between Q-1 _k and Q-2 _k (k = x or y)		< 1
	Between I and Q (max)		< 5
Optical Path Difference ¹ (Skew, among L → Outputs)	Between I-1 _k and I-2 _k (k = x or y)	<i>ps</i>	< 1
	Between Q-1 _k and Q-2 _k (k = x or y)		< 1
	Between I and Q (max)		< 5
Polarization extinction ratio ¹ (for either S or L)		<i>dB</i>	> 18
Max. Input Optical Power		<i>mW</i>	300
Operating Temperature		<i>°C</i>	0 ~ 65
Storage Temperature		<i>°C</i>	-40 ~ 85
Size (L x W x H) ²		<i>mm</i>	48 x 31 x 13
Fiber Type	Signal Input Port	-	SMF-28 with 900 μm tight buffer
	Lo-Input Port	-	PM with 900 μm loose tube
	All Output Ports	-	SMF-28 with 900 μm tight buffer
Fiber Pigtail Length	Signal Input Port	<i>mm</i>	1000 ± 100
	Lo-Input Port	<i>mm</i>	1000 ± 100
	All Output Ports	<i>mm</i>	1000 ± 100
Connector Type ³	Signal Input Port		FC/APC
	Lo-Input Port		FC/APC
	All Output Ports		FC/APC
PM Fiber Alignment with APC Key (if applicable)		-	Slow Axis aligned to the key

Notes:

1. Over the stated spectral and operating temperature ranges and all polarization states.
2. Not including ten collimator sleeves extending from one longer side by 17 mm.
3. *FC/APC* connectors for all ports

6.4. Mechanical Properties

6.4.1 Device Dimension

Size (L x W x H)	mm	48 x 31 x 13
------------------	----	--------------

6.4.2 Mechanical Drawings

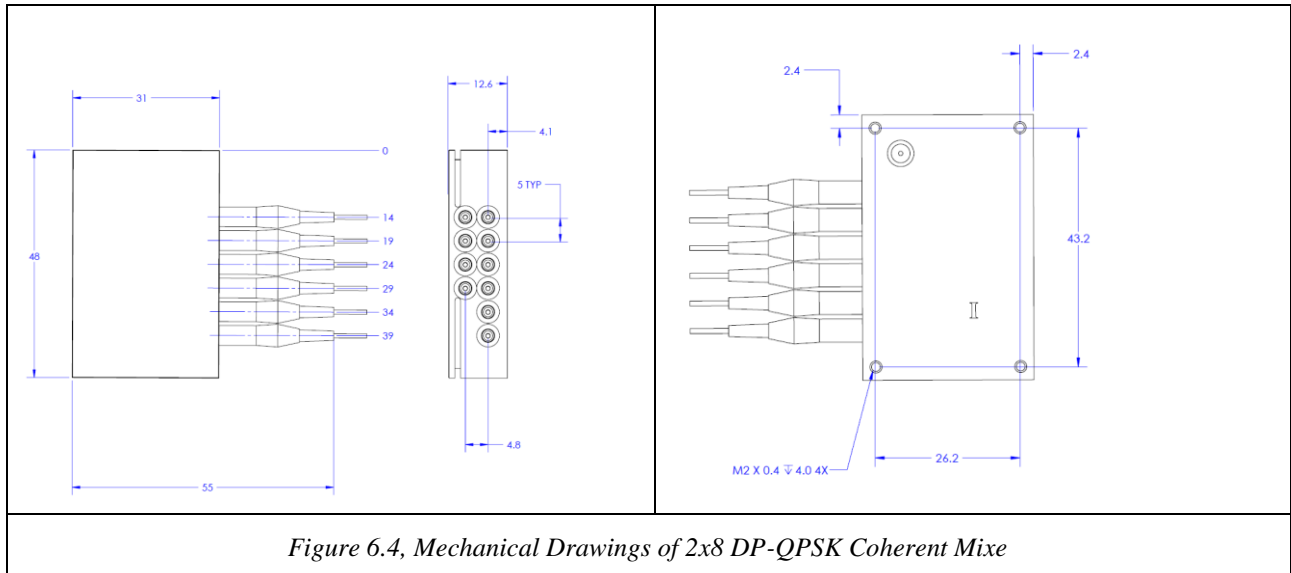

6.5. Port Assignment

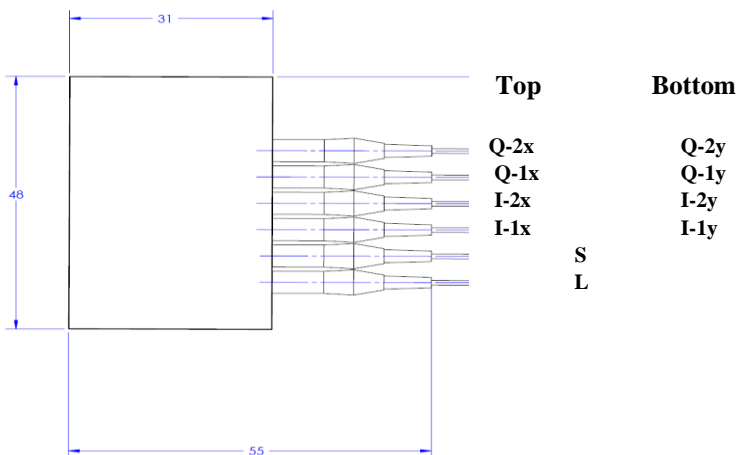

Figure 6.5, Port Definitions of 2x8 DP-QPSK Coherent Mixer

6.6 Part Numbers of 2x8 DP-QPSK Coherent Mixers

Table 6.6, List of Part Numbers of 2x8 DP-QPSK Coherent Mixer

Wavelength Band	Product Description	MPN	
		Std Grade: 90+/-10deg	Premium Grade: 90+/-5deg
C-Band	2x8 DP-QPSK Coherent Mixer, C-Band , PMF for Local-Input, SMF for Signal- Input; SMF for All Outputs, FC/APC for ALL Ports.	HB-C0GFAS001	HB-C1GFAS001
L-Band	2x8 DP-QPSK Coherent Mixer, L-Band , PMF for Local-Input, SMF for Signal- Input; SMF for All Outputs, FC/APC for ALL Ports.	HB-L0GFAS218	HB-L1GFAS218
C+L Band	2x8 DP-QPSK Coherent Mixer, C+L Band , PMF for Local-Input, SMF for Signal- Input; SMF for All Outputs, FC/APC for ALL Ports.	HB-T0GFAS053	HB-T1GFAS053
O-Band: 1310+/-20nm	2x8 DP-QPSK Coherent Mixer, O-Band (1310+/-20nm), PMF for Local- Input, SMF for Signal- Input; SMF for All Outputs, FC/APC for ALL Ports.	HB-Q0GFAS1310	HB-Q1GFAS1310
O-Band: 1275+/-20nm	2x8 DP-QPSK Coherent Mixer, O-Band (1275+/-20nm), PMF for Local- Input, SMF for Signal- Input; SMF for All Outputs, FC/APC for ALL Ports.	HB-Q0GFAS1275	HB-Q1GFAS1275
O-Band: 1345+/-20nm	2x8 DP-QPSK Coherent Mixer, O-Band (1345+/-20nm), PMF for Local- Input, SMF for Signal- Input; SMF for All Outputs, FC/APC for ALL Ports.	HB-Q0GFAS1345	HB-Q1GFAS1345

7. 2x8 DP-QPSK Coherent Mixer with Single-ended PD Outputs

7.1 Functional Block Diagram

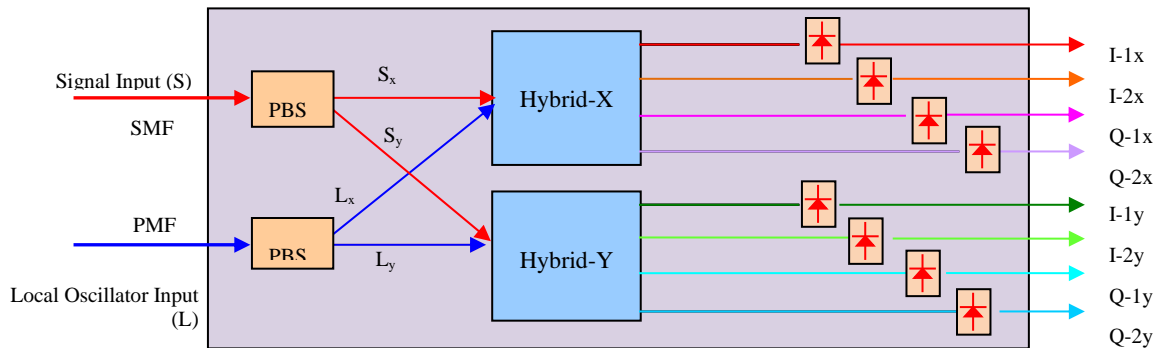

Figure 7.1, Functional block diagram of the coherent receiver with single-ended PD output

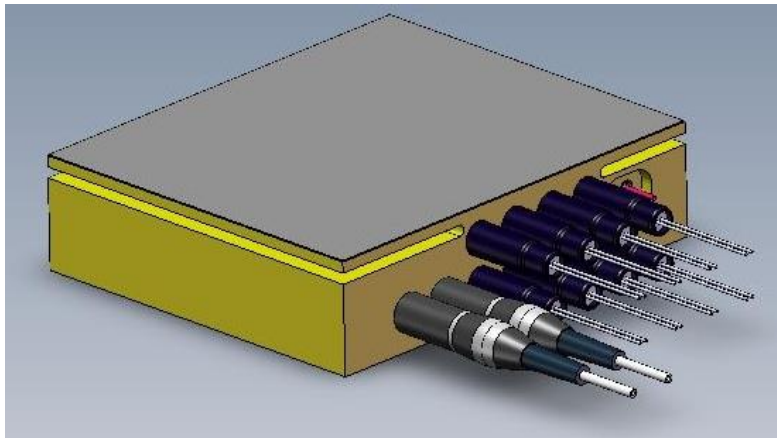

Figure 7.2, 2x8 DP-QPSK Coherent Mixer with single-ended PD outputs

7.2 Performance

The 2x8 DP-QPSK Coherent Mixer's performance is same as described in Section 6, while the single-ended photodetector's performance are same as those described in Section 3.3 – there are three different speed (bandwidth) of the PDs: 0.6GHz, 4GHz and 7GHz.

7.3 List of Part Numbers of 2x8 DP-QPSK Coherent Mixer with Single-ended PD Outputs

Wavelength Band	Part Number	I/Q Phase (Deg)	Type of Fiber		Photodiode Bandwidth (GHz)	Note
			Signal-Port	Local-Port		
C-Band	RX-GC0600S202	90 +/- 10	SMF	PMF	0.6	
	RX-GC0600S203	90 +/- 5	SMF	PMF	0.6	
L-Band	RX-GL0600S208	90 +/- 10	SMF	PMF	0.6	
	RX-GL0600S209	90 +/- 5	SMF	PMF	0.6	
C+L Band	RX-GT0600S204	90 +/- 10	SMF	PMF	0.6	
	RX-GT0600S205	90 +/- 5	SMF	PMF	0.6	
O - Band	RX-GQ0600S206	90 +/- 10	SMF	PMF	0.6	
	RX-GQ0600S207	90 +/- 5	SMF	PMF	0.6	1310+/-20nm

Notes:

- 1) *By default design, SMF is for Signal-Input, while PMF for Loca-Input. PMF for both Signal- and Local- inputs are available. Contact Optoplex*
- 2) *Contact Optoplex for the part numbers of higher-bandwidth of PDs, i.e., 3GHzx and 7GHz versions*

8. 2x8 DP-QPSK Coherent Mixer integrated with Balanced Receivers

8.1 Functional Block Diagram

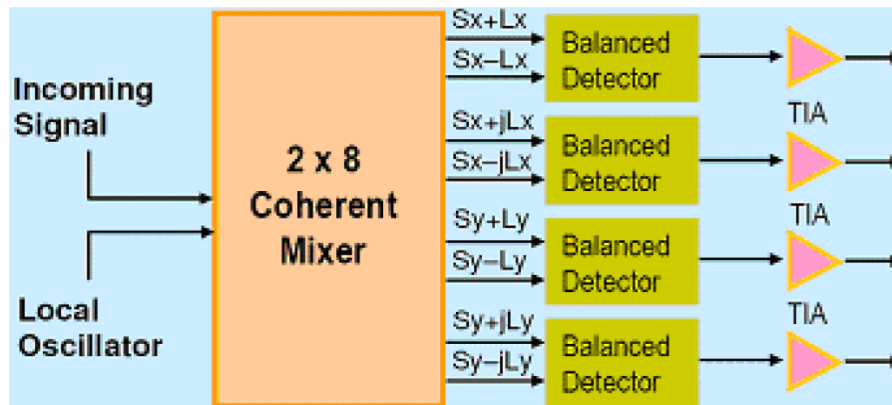

Figure 8.1, Functional block diagram of 2x8 DP-QPSK Coherent Mixer with Balanced Receivers

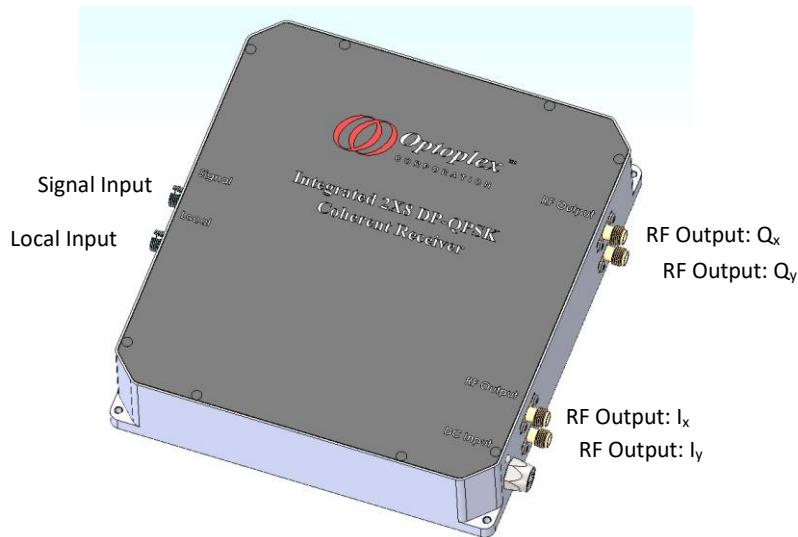

Figure 8.2, 2x8 DP-QPSK Coherent Mixer with Balanced Receivers

8.2 Performance Specifications

The 2x8 DP-QPSK coherent mixer performance is same as that described in Section-6, while the balanced receivers are same as those used in Section 4.4. The available bandwidth of the balanced receivers are 15, 100, 200, 400, 700, 1200 and 1600MHz.

8.3 List of Part Numbers of 2x8 DP-QPSK Coherent Mixer with Balanced Receivers

Wavelength Band	Receiver's Bandwidth (MHz)	I/Q Phase	P/N	Note
C-Band	15	+/-10	RX-KC0015S911xx	
		+/-5	RX-KC0015P911xx	
	100	+/-10	RX-KC0100S901xx	
		+/-5	RX-KC0100P901xx	
	200	+/-10	RX-KC0200S903xx	
		+/-5	RX-KC0200P903xx	
	350	+/-10	RX-KC0350S905xx	
		+/-5	RX-KC0350P905xx	
	400	+/-10	RX-KC0400S907xx	
		+/-5	RX-KC0400P907xx	
	700	+/-10	RX-KC0700S909AC	
		+/-5	RX-KC0700P909AC	
	1200	+/-10	RX-KC1200S913AC	
		+/-5	RX-KC1200P913AC	
	1600	+/-10	RX-KC1600S915AC	
		+/-5	RX-KC1600P915AC	

Notes

- 1) In the part numbers of 15 ~ 400MHz, the last two digits ".....xx":
 - xx = DC, DC-coupled RF outputs
 - xx = AC, AC-coupled RF outputs
- 2) Products are available for L-, C+L, and O-Band as well. Contact Optoplex for details.

9. 2x4 DP-QSK Coherent Mixer for Single-ended Detection

9.1 Functional Diagram

Unlike the 2x8 DPSK coherent mixer described in Section-6, in which the mixer has differential outputs suitable for balanced detection, the 2x4 DP-QPSK coherent mixer described in this section has single-output of I and Q for each polarization and it is a low-cost version for single-ended coherent detection.

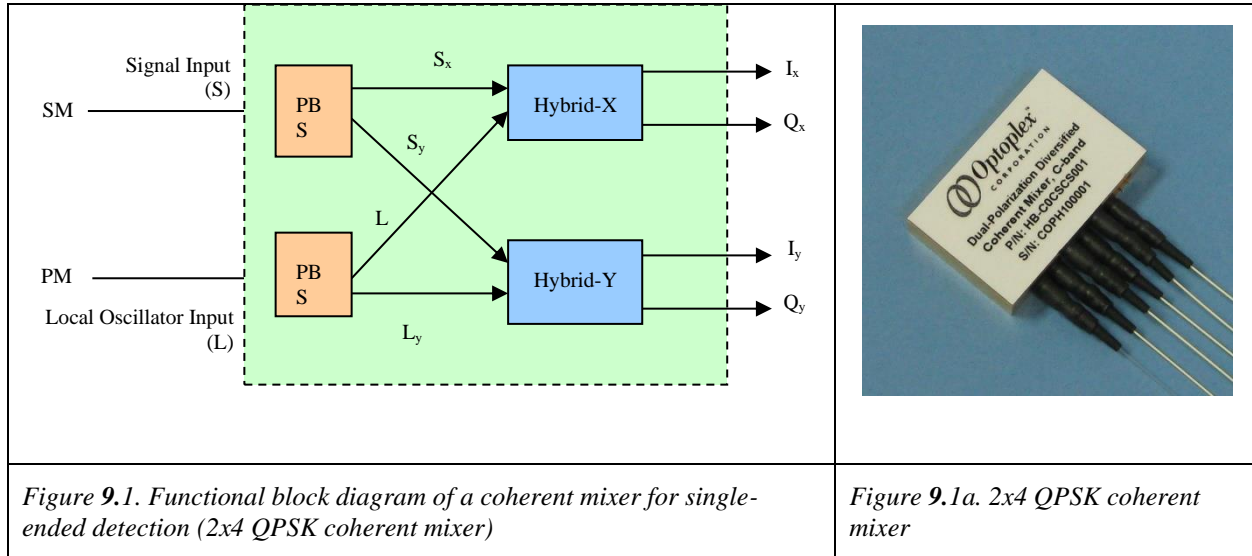

9.2 Port Definition

Table 9.1. Function definition of a 2x4 QPSK coherent mixer

Port	Function	Phase Difference	Polarization	Value	Note
1	Local			L	
2	Signal			S	
3	I _x	0	x	$S_x + L_x$	
4	Q _x	$\pi/2$	x	$S_x + jL_x$	
5	I _y	0	y	$S_y + L_y$	
6	Q _y	$\pi/2$	y	$S_y + jL_y$	

9.3 Performance Specification

Table 9.2. Performance Specifications of 2x4 DP-QPSK Coherent Mixer

Parameter		Unit	Specification
Wavelength Range (C-Band)		<i>nm</i>	1525 ~ 1570
Phase Difference ¹ (between I _k and Q _k), k=x or y		<i>degree</i>	90 ± 10
Insertion Loss ¹ (not including connector)	S (polarization scrambled) → I _x , I _y , Q _x , Q _y	<i>dB</i>	9 ~ 12
	L (45° linear polarized) → I _x , I _y , Q _x , Q _y	<i>dB</i>	9 ~ 12
Insertion Loss Uniformity ¹	Among S → I _x , I _y , Q _x , Q _y	<i>dB</i>	< 1.2
	Among L → I _x , I _y , Q _x , Q _y	<i>dB</i>	< 1.2
Optical Return Loss		<i>dB</i>	> 27
Optical Path Difference ¹ (Skew, among S → I _x , I _y , Q _x , Q _y)		<i>ps</i>	< 1
Optical Path Difference ¹ (Skew, among L → I _x , I _y , Q _x , Q _y)		<i>ps</i>	< 1
Polarization extinction ratio ¹ (for either S or L)		<i>dB</i>	> 18
Max. Input Optical Power		<i>mW</i>	300
Operating Temperature		<i>°C</i>	0 ~ 65
Storage Temperature		<i>°C</i>	-40 ~ 85
Size (L x W x H) ²		<i>mm</i>	48 x 31 x 10
Fiber Type (for S, I _x , I _y , Q _x , Q _y)		-	SMF-28 with 900 μm tight buffer
Fiber Type (for L)		-	PM with 900 μm loose tube
Fiber Pigtail Length		<i>m</i>	1.0 ± 0.1
Connector Type		-	FC/APC

Notes:

1. Over the stated spectral and operating temperature ranges and all polarization states.
2. Not including six collimator sleeves extending from the package.

9.4 Part Numbers and Ordering Info

Table 9.3, List of Part Numbers of 2x4 DP-QPSK Coherent Mixer

Wavelength Band	Fiber			I/Q Phase	Part Number	Note
	Signal - Input	Local - Input	Outputs			
C	SMF	PMF	SMF	90+/-10	HB-C0BFAS083	
	SMF	PMF	SMF	90+/-5	HB-C0BFAS084	

Notes:

- 1) Other wavelength band's are available, such as L-, C+L and O-Band. Contact Optoplex for details.
- 2) 2x4 DP-QPSK coherent mixer integrated with receivers products are NOT available.

10. 180deg Optical Hybrids

10.1 Functional Diagram

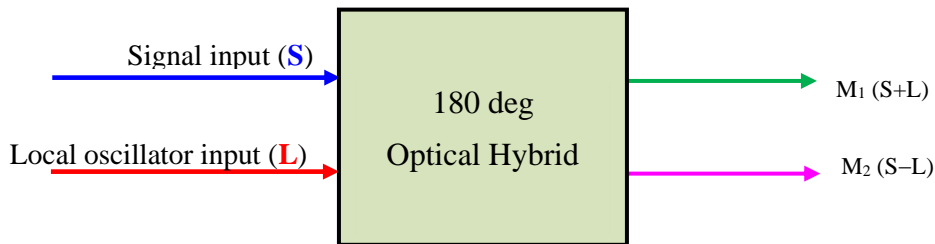

Figure 10.1, Functional Block Diagram of 180deg Hybrid

Table 10.1, Port Assignment of 180deg Hybrid

Port	Function	Phase Difference	Value
1	Local		L
2	Signal		S
3	M ₁	0	S + L
4	M ₂	π	S - L

10.2 Performance Specifications

Table 10.2, Performance Specification of 180deg Hybrid

Parameter		Unit	Specification	Notes
Wavelength Range (C- Band)		<i>nm</i>	1550 +/- 10	
Phase Difference ¹ (between M ₁ , M ₂ and M ₃ ,		<i>deg</i>	180 +/- 5	
Insertion Loss ¹ (without connector)	S→M _i	<i>dB</i>	< 6.0	
	L→M _i	<i>dB</i>	< 6.0	
Insertion Loss Difference ¹	S→M ₁ and S→M ₂	<i>dB</i>	< 0.8	
	L→M ₁ and L→M ₂	<i>dB</i>	< 0.8	
	Between all other	<i>dB</i>	< 0.8	
Optical Return Loss		<i>dB</i>	> 25	
Optical Path Difference (skew, between M ₁)		<i>ps</i>	< 6	
Fiber Type	Signal Input Port	/	SM Fiber or PM Fiber ¹⁾	
	Local Input Port	/	SM Fiber or PM Fiber ¹⁾	
	Outputs	/	SMF-28 with 900-μm tight buffer	
Pigtail Length	Signal Input Port	<i>mm</i>	1000 +/- 100	
	Local Input Port	<i>mm</i>	1000 +/- 100	
	Outputs	<i>mm</i>	1000 +/- 100	
Type of Connector	Signal Input Port		FC/APC	
	Local Input Port		FC/APC	
	Outputs	-	FC/APC	
Polarization Extinction Ratio (PER)		<i>dB</i>	> 16 ²⁾	
Polarization Axis Alignment				

Notes:

- 1) Customer can specify the type of the input fiber for either or both inputs
- 2) When PM fiber is used.

10.3 Mechanical Drawings

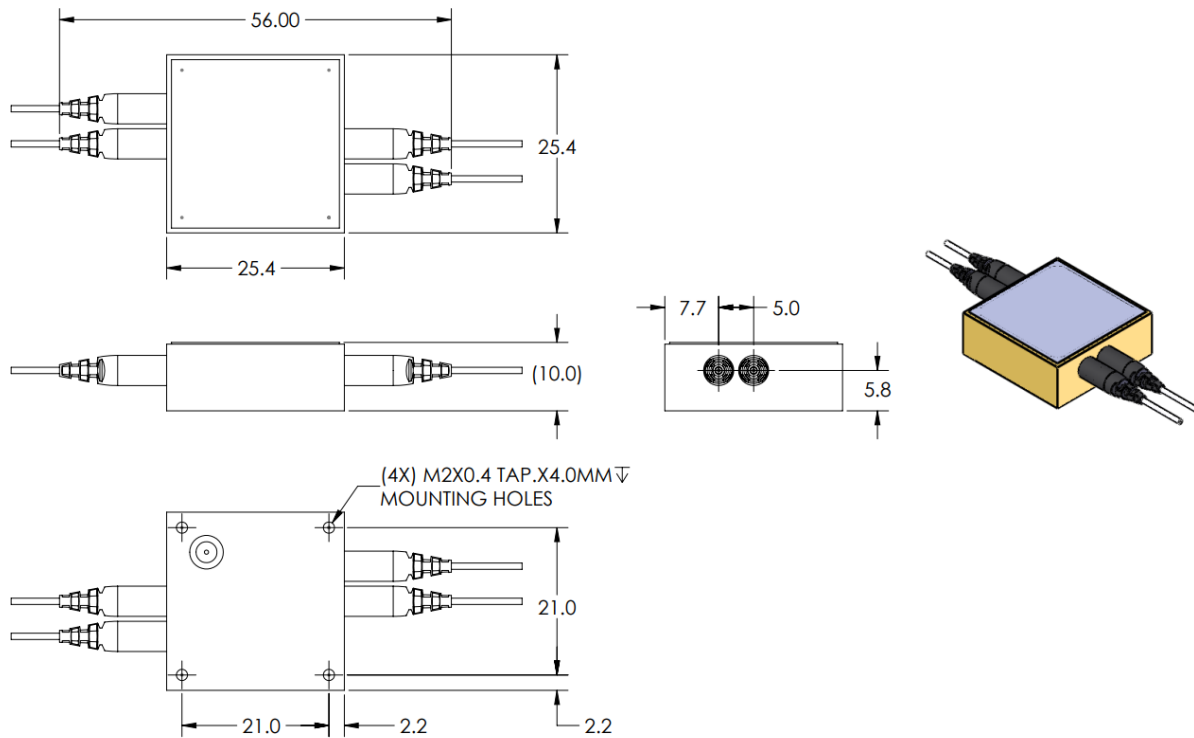

Figure 10.2, Mechanical drawings of 180deg Hybrid

10.4 List of Part Numbers and Ordering Information

Table 10.3, Part Numbers of 180deg Hybrid

Wavelength Band	Fiber			I/Q Phase	Part Number	Note
	Signal - Input	Local - Input	Outputs			
C	SMF	SMF	SMF	180+/-5	HB-C0KFAS180	
	PMF	PMF	SMF	180+/-5	HB-C0KFAX180	
	PMF	PMF	PMF	180+/-5	HB-C0KFAP180	